



**HYDRAULIC HAND PALLET TRUCK
MODELS: MP775/MP776**

INSTRUCTION MANUAL



WARNING!

- Read and understand the entire operator's manual before using the pallet truck.
- Don't load pallet truck beyond rated capacity of 11,000 lbs.
- Secure load before transporting.
- Keep the load centered on the pallet.
- Don't operate loaded pallet truck on ramps or inclines.
- Always wear appropriate safety shoes.
- Never leave a loaded pallet truck unattended in the raised position; always lower load to the floor.

PALLET TRUCK ASSEMBLY

Note: Individual trucks are assembled and ready to use. Pallet trucks purchased in crate quantities (6 units to a crate) require some assembly.

Tools needed for assembly: hammer, flat screwdriver, 14mm wrench

To attach handle assembly to the frame:



1.

***** IMPORTANT - SAFETY *****

Verify that spring safety pin is in place. The pin should be well rested in the holes situated on each side of the pump housing. If the safety pin is not rested properly in one of the holes, put pressure on the spring using a "C" clamp pushing down on the pump stem. Once pressure is relieved on the pin, reinsert properly and remove clamp slowly,



2.

Insert handle pin into corresponding holes and using a hammer, drive in one spring pin on one side only.



3.

Insert handle pin without the handle and verify that the center hole is facing you.



4.

If handle pin's center hole is facing away from you, insert pin from other side.

***** IMPORTANT - FACT *****

The up/down lever's chain passes through this center hole. If left this way, the chain will have an "S" form and be under too much tension, making the up/down lever difficult to use accurately.

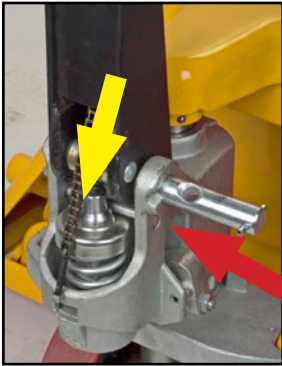

5.

***** IMPORTANT - CHAIN*****

Before this step, make sure to feed the chain on the outside of the piston stem roller (see yellow arrow). If left in its proper position, it will not be possible to insert the handle pin and chain, breakage may occur.

Align handle holes with pump housing holes and push through handle pin (see red arrow)



6.

Make sure that handle pin is completely through the handle and resting on the other side.



7.

Pull down on the handle to release the tension on the safety pin. CAREFULLY remove the safety pin.



8.

Feed the chain and nut first back inside the handle THROUGH the handle pin's center hole.

*****IMPORTANT - TIP *****

Release the up/down lever to its lowest position to make the process easier.



9.

Once the chain is in the proper position, check to see that it moves freely and that it is not obstructed.



10.

Using both hands, push on the valve cam to raise the hook inside the housing and feed the end of the chain in the cam. (see image at right)



11.

Pump the lever a few times to raise the forks. Put the up/down lever to its NEUTRAL position. Using a 14mm wrench and a flat screwdriver, adjust the valve cam so that the forks don't lower or rise (if handle is pumped) at this position.



12.

***** IMPORTANT - FINAL CHECK *****

Test all the features of the pallet truck before this step. The handle should be pumped with full strokes to prime and eliminate air in the system. The up/down lever should be checked at the handle's lowest position for this puts the most tension on the chain. Once the pallet truck is adjusted properly and is performing well, drive in the second spring pin using a hammer.

OPERATING PALLET TRUCK

To raise the forks, place handle lever in UP position (bottom part of the handle slot).
See Figure 2.

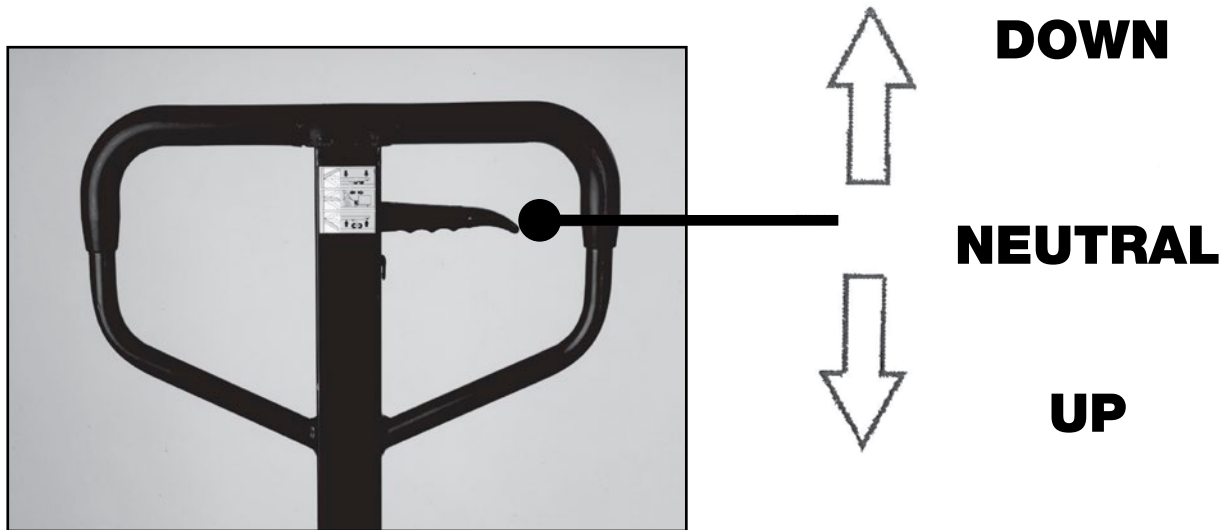

Figure 2

To lower forks, pull lever to DOWN position (upper part of the slot).
To freely move the handle, set the lever in NEUTRAL (center notch of the slot).

To lift a load:

1. Lower forks to lowest position.
2. Insert forks under load or into pallet.
3. Place lever in UP position (bottom part of the slot).
4. Move handles up and down until forks reach desired height.

To move a load:

1. Place lever in NEUTRAL position (center notch of the slot).
2. Pull or push to desired location.

To lower a load:

1. Pull lever to the DOWN position (upper part of the slot).
2. Pull forks away from load.

TECHNICAL PARAMETER

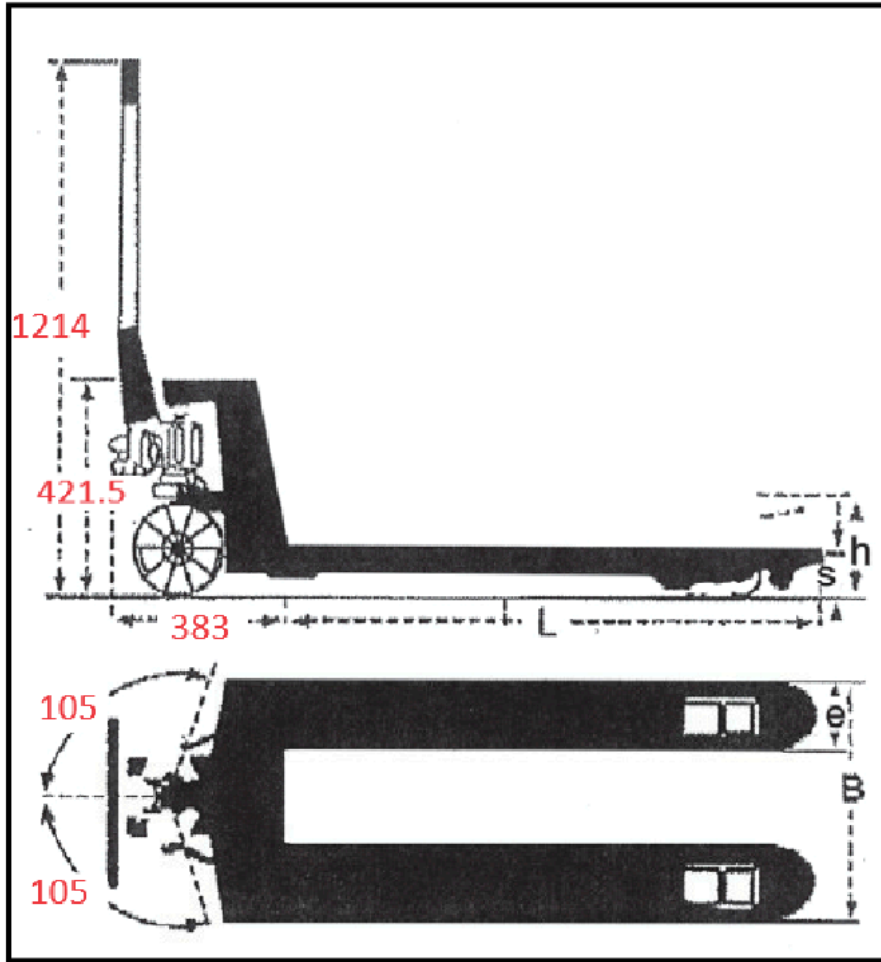

Model No. (Assembled)	MP775	MP776
Capacity	5500 lbs.	
	2500 kg	
H - Maximum Raised Height	7-1/2"	
	190 mm	
S - Lowered Height	3"	
	75 mm	
L - Fork Length	48"	
	900 mm	
E - Fork Width	6-1/4"	
	160 mm	
B - Fork Outside Distance	20-1/2"	27"
	520 mm	685 mm
Dimensions of the steer wheel	7" x 2"	
	180 mm x 50 mm	
Dimensions of the Load wheel	3" x 3-5/8"	
	74 mm x 93 mm	

TROUBLESHOOTING

Possible problems could arise in the operation of your hydraulic pallet truck. Their probable cause(s) and corrective action(s) follow:

Condition	Probable Causes	Corrective Action
Hydraulic unit does not lift	Oil low in tank	Make sure there is no till leakage from valve and add oil.
	Relief valve not seated properly or air in the system	See "Cleaning Relief Valve" in this manual.
	Defective pressure seal in main cylinder	Consult authorized service centre.
	Relief valve not adjusted properly	Adjust valve by pressure adjustment screw
Once lifted truck lowers by itself	Relief valve not seated properly	See "Cleaning Relief Valve" in this manual.
	Defective pressure seal in main cylinder	Consult authorized service centre
	Relief valve not adjusted properly	Adjust valve by pressure adjustment screw
	Oil leakage	Consult authorized service centre
Fork does not lower	Cam chain broken	Replace cam chain.
	UP-DOWN cam nut out of adjustment	Refer to "Adjusting UP-DOWN Cam" in this manual.
	Broken fork rods and linkage	Consult authorized service centre
	Cam chain lock-nut fallen off	Replace cam chain lock-nut
Lever does not set at NEUTRAL position	Relief valve not adjusted properly	Adjust valve by pressure adjustment screw

Cleaning Relief Valve:

Over time, relief valve may become clogged with debris and will not work properly. To clean relief valve, flush our hydraulic system as follows:

Pump handle quickly, raising pallet truck to full extent.

Then, quickly release pumping action.

Adjusting UP-DOWN Cam

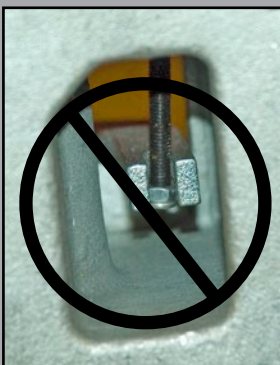

DO NOT adjust the up/down lever control using the lock nut at the end of the handle chain. If nylon locking threads are removed from the screw threads, rolling vibration will cause the nut to unscrew and fall off, leaving the up/down lever unusable.

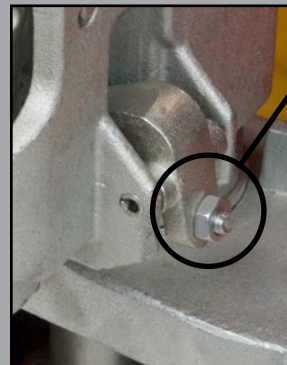

Use proper set screw and lock nut adjustment located on the side of the pump. This feature was designed to ease the pallet truck adjustment. Tools required are: flat screwdriver and a 14mm wrench.

HYDRAULIC HAND PALLET TRUCK ASSEMBLY

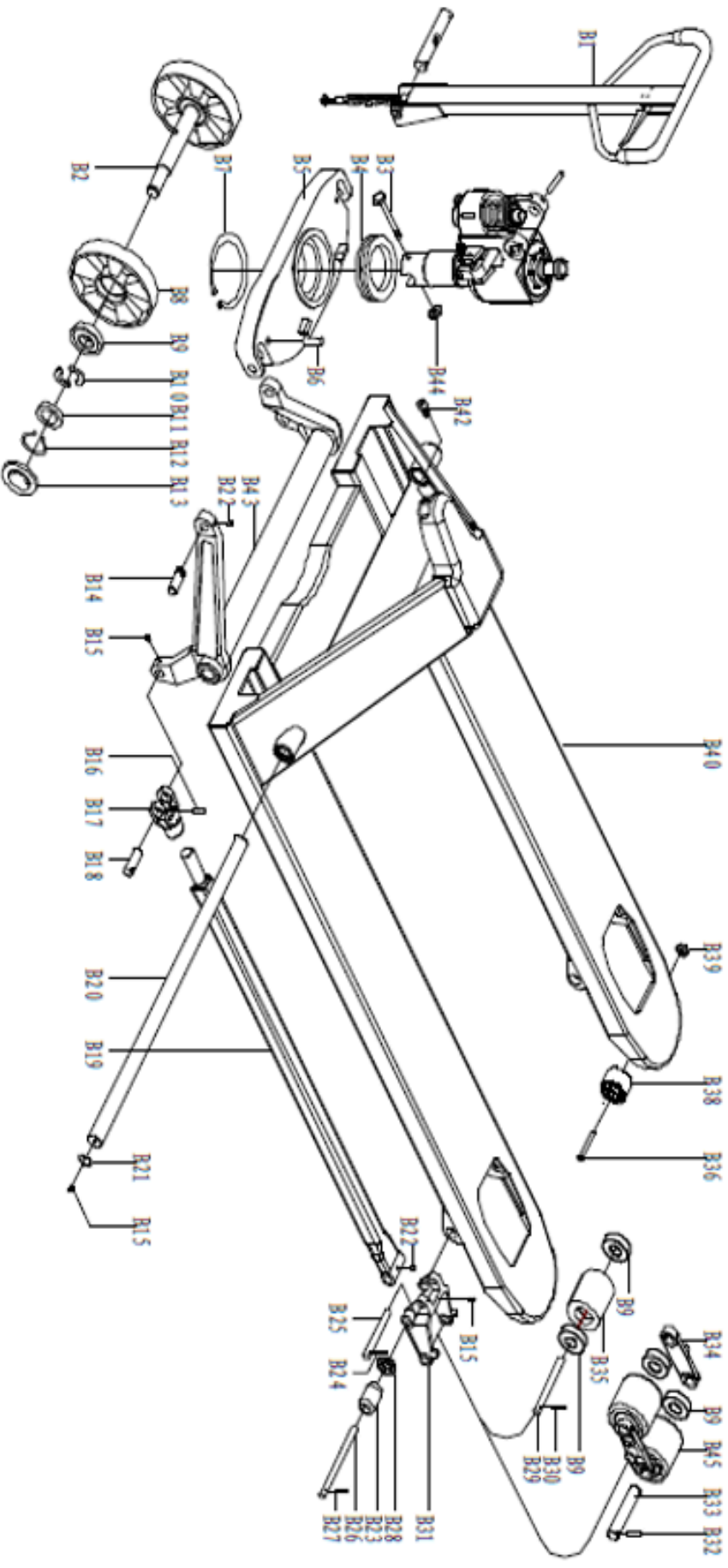

No.	Vend Model	DESCRIPTION	Qty.
B1	MN301	Handle	1
B2	MP958	Big Wheel Shaft	1
B3	GB5782-86	Bolt M8X55	1
B4	GB306-64	Bearing 8111	1
B5	BF-03	Supporting Base	1
B6	GB879-86	Spring Pin 5X32	2
B7	MP959	Ring For Axle 55	1
B8	MN303	Big Wheel	2
B9	MK984	Bearing 60204	8/12
B10	AF-05	Half Ring	4
B11	AF-06	Washer	2
B12	MP960	Ring For Axle 20	2
B13	MN343	Dust Cover	2
B14	BF-04	Pin 16X40	2
B15	GB1152-79	Oiler M6	6
B16	GB879-86	Spring Pin 5X28	2
B17	AF7-05	Joint	2
B18	DF-01	Pin 16X44	2
B19	AF7B.1-00	Straight Tappet	1
B20	AF-02	Long Shaft	1
B21	GB893-86	Ring For Hole 25	2
B22	GB1155-74	Oiler 6	4
B23	MN318	Roll SHEATH	2

No.	Vend Model	DESCRIPTION	Qty.
B24	GB879-86	Spring Pin 5X28	2
B25	SYBC.5-06	Shaft 16X85	2
B26	DF-04	Shaft 20X152	2
B27	GB879-86	Spring Pin 5X35	2
B28	AF-04	Roll Ring	4
B29	MP961	Shaft 20X122	2
B30	MP962	Spring Pin5X32	2
B31	MP963	Frame of Wheel	2
B32		-	8
B33		-	4
B34		-	4
B35	MP964	Wheel 80/70X93	2
B36	MP965	Bolt M6X50	2
B38	MN305	Wheel	2
B39	MP762	Lock Nut M6	2
B40	BF4-00	Fork Frame	1
B42	GB70-85	Bolt M6X12	1
B43	BF3-00	Rocker Arm	1
B44	GB889-86	Lock Nut M8	1
B45	AF7-01	Wheel 80/74X70	4

PUMP PART LIST

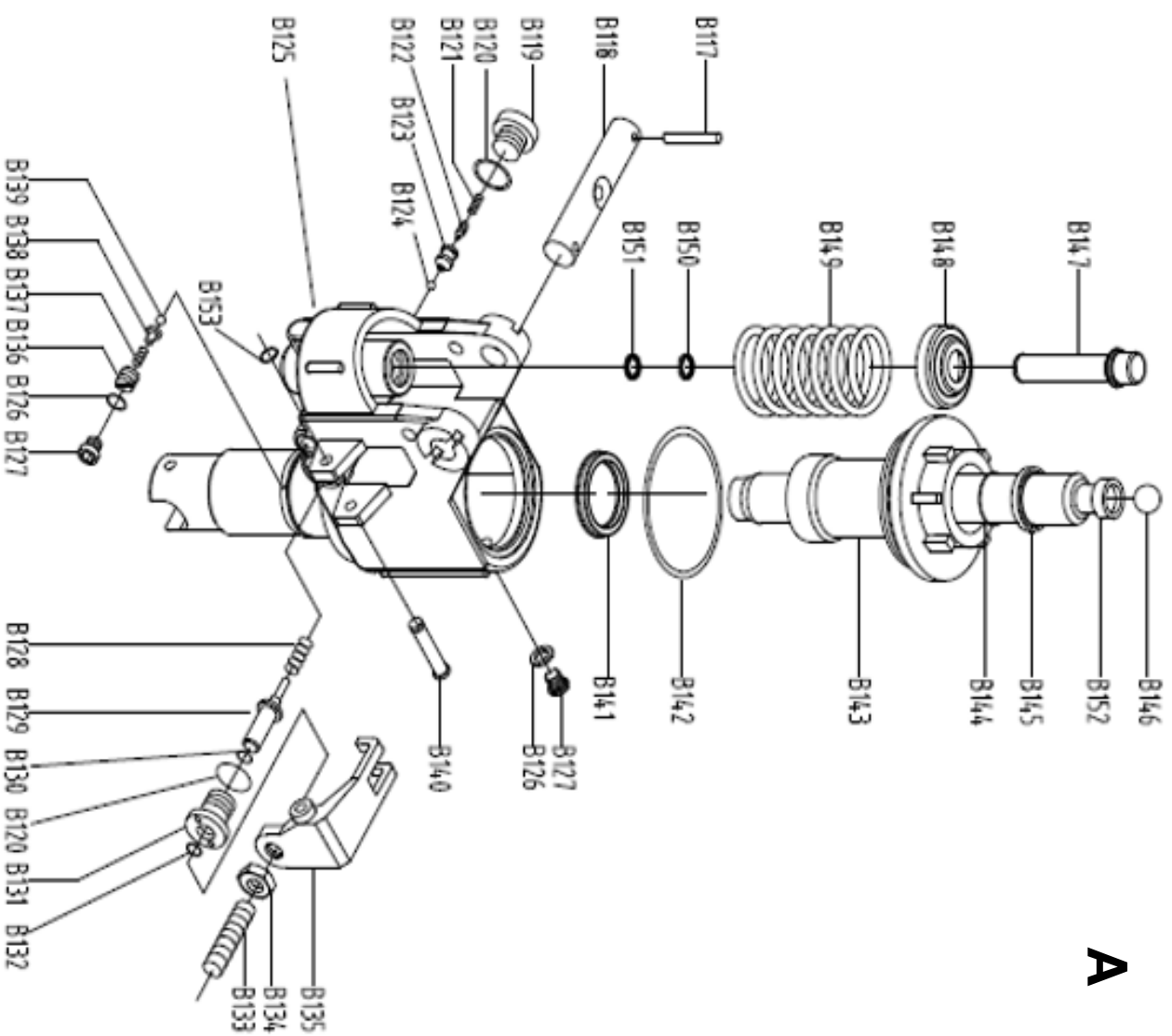
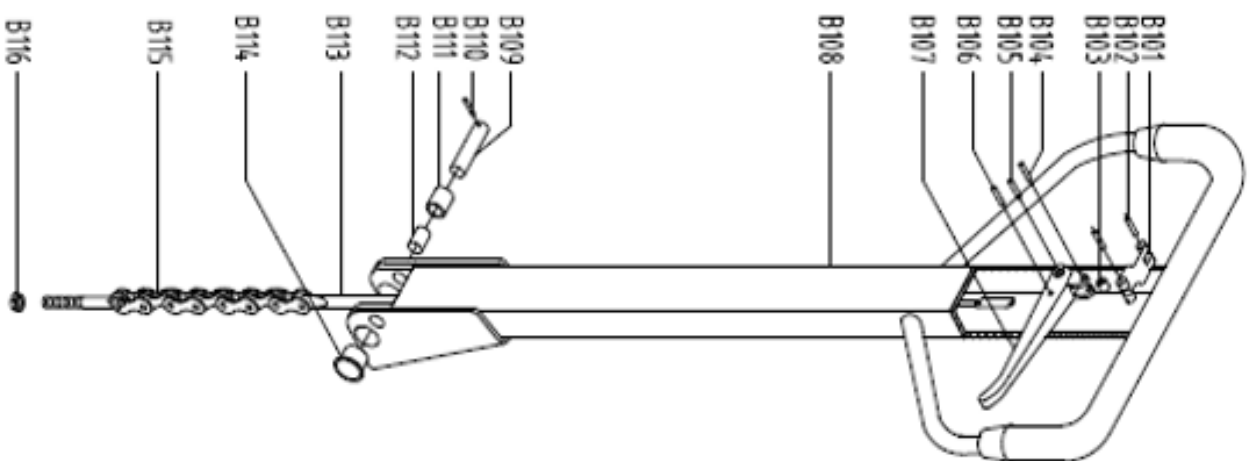

A

No.	Vend Model	DESCRIPTION	Qty.
B101	MP966	Blade Spring	1
B102	MP967	Spring Pin 4X30	2
B103	MP968	Roller	1
B104	MP969	Spring Pin 4X20	1
B105	MP970	Spring Pin 6X30	1
B106	MP971	Spring Pin 4X20	1
B107	MP972	Handle	1
B108	BF.1.1-00	Handle Tube	1
B109	DF1.2-04	Shaft	1
B110	GB879-86	Spring Pin 3X20	1
B111	CN.2-13	Pressure Roller	1
B112	CSB10	Bush 1220	1
B113	MP973	Pull Pole	1
B114	MP974	Bush SF-1F2015	2
B115		Chain C-6-9-.04A +	
B116	MP975	Lock Nut M5	1
B117	MP976	Spring Pin 5X35	2
B118	MP977	Shaft	1
B119	MP978	Plug M20X1.5	1
B120	MP979	Copper Washer 20	2
B121	MP980	Spring	1
B122	SYBC2-07	Spindle of Valve	1
B123	SYBC.2-08	Seat of Valve	1
B124	GB308-77	Ball 6.35	1
B125	BF.2.1-00	Base	1
B126	JB982-77	Copper Washer 10	2
B127	CN.2-17	Plug M10X1	2

No.	Vend Model	DESCRIPTION	Qty.
B128	MP981	Spring 1.2X9.8X22	1
B129	MP982	Strike Pin	1
B130	MP983	O-Ring 7X1.8	1
B131	MP984	Seat of Strike Pin	1
B132	MP985	O-Ring 8X2.65	1
B133	GB73-85	Bolt M6X25	1
B134	GB6170-86	Nut M6	1
B135	MP986	Lever Plate	1
B136	CN.2-28	Bolt M10X1	1
B137	CN.2-27	Spring 2X8X16	1
B138	CN.2-26	Ball Base	1
B139	GB308-77	Ball 5	1
B140	BF.2-3	Pin 8X58	1
B141	UHS31.5	Y-Ring 31.5	1
B142	GB3452.1-82	O-Ring 65X2.65	1
B143	BF.2-2a	Cylinder Cap 31.5	1
B144	GB3452.1-82	O-Ring 31.5X3.55	1
B145	DH31.5	Dust Ring 31.5	1
B146	GB308-77	Ball 19.05	1
B147	MN362	Pump Plunger	1
B148	MN363	Washer	1
B149	MP987	Spring	1
B150	MP988	Dust Ring 18	1
B151	MP989	Y-Ring 18	1
B152	AF.2-4	Piston Rod	1
B153	MP990	Ring For Axle 8	1
A	MP994	Pump Assembly	1